

## PILOT OPERATED PRESSURE RELIEF VALVES

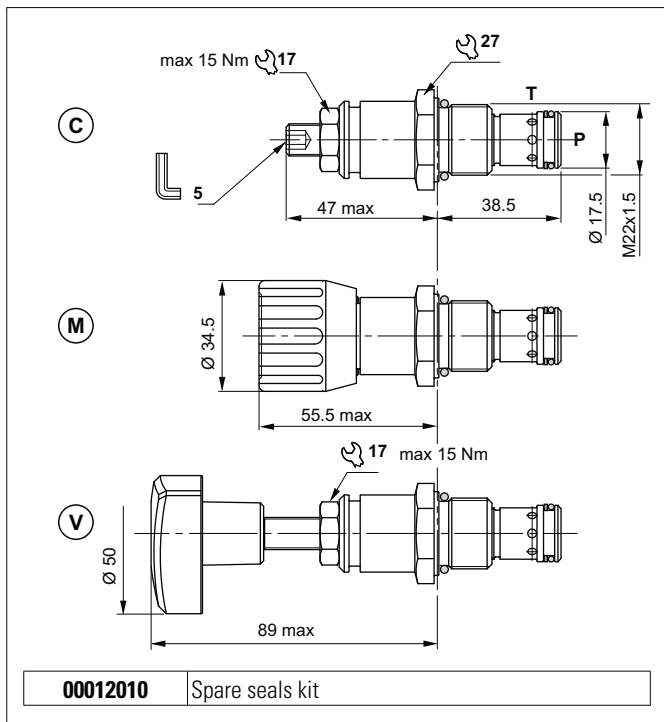

The pilot-operated relief valve limits the pressure in the hydraulic circuit. Slight leakage is tolerated for this type of valve. It raises the safety level by making it impossible for the plant operators to set a higher pressure rating, than that specified in the catalogue. It has a pack spring with a mechanical stop. It has a galvanised steel body. The tapered pilot poppet and cylindrical main plunger are made from tempered and ground steel.

### HYDRAULIC FEATURES

Max. opening pressure	350 bar
Setting range:	
Spring 1 (white)	max 50 bar
Spring 2 (yellow)	max 140 bar
Spring 3 (green)	max 350 bar
Max. Flow	100 l/min
Hydraulic fluid	DIN 51524 Mineral oils
Fluid viscosity	10 ÷ 500 mm <sup>2</sup> /s
Fluid temperature	-25°C ÷ 75°C
Ambient temperature	-25°C ÷ 60°C
Max. contamin. level class with filter	ISO 4406:1999 - class 19/17/14
Weight	0.18 kg
Tightening torque	30 ÷ 40 Nm
Cavity (M22x1.5)	CN047003 (See section 15)

The minimum permissible setting pressure depending on the spring: see curves below

### HYDRAULIC SYMBOL

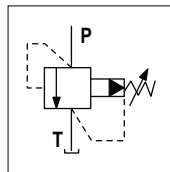

### PRESSURE-FLOW RATE

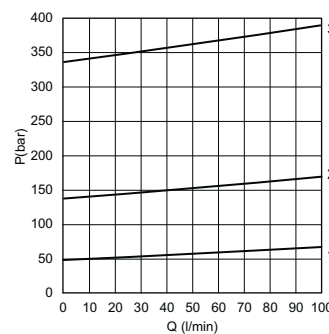

### MIN.SETTING PRESSURE

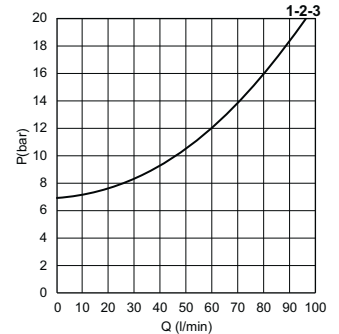

1 = CMP30.1.. - 2 = CMP30.2.. - 3 = CMP30.3..

Fluid used: mineral based oil with viscosity 46 mm<sup>2</sup>/s at 40°C.

### ORDERING CODE

