

## ONE-WAY CHECK VALVES (FOR POWER PACKS SERIES FP)

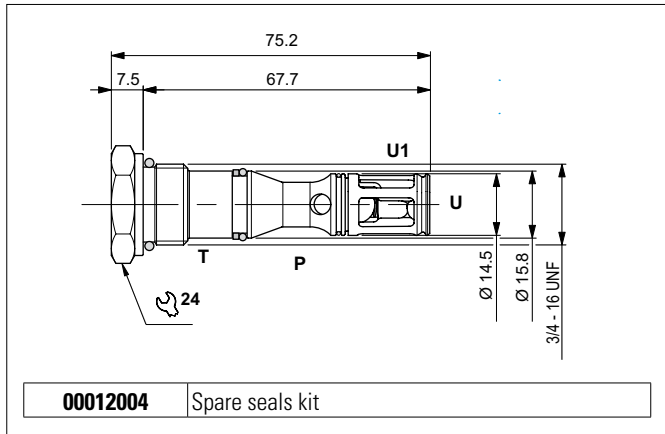

The check-valves permit one-directional oil flow only. On the opposite side the sealing is guaranteed by a ball steel poppet. The spring permits an easy valve installation in any position. External steel body protected on surface by zinc plating.

### HYDRAULIC FEATURES

Max. opening pressure	320 bar
Max. Flow	20 l/min
Max. Leakage (0 ÷ 5 drops/min)	0 ÷ 0.25 cm <sup>3</sup> /min
Hydraulic fluid	DIN 51524 Mineral oils
Fluid viscosity	10 ÷ 500 mm <sup>2</sup> /s
Fluid temperature	-25°C ÷ 75°C
Ambient temperature	-25°C ÷ 60°C
Max. contamin. level class with filter	ISO 4406:1999 - class 19/17/14
Weight	0.09 kg
Tightening torque	25 ÷ 30 Nm
Cavity (3/4 - 16 UNF)	CD018013 (See section 15)

### HYDRAULIC SYMBOL

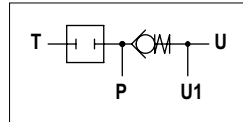

### PRESSURE DROPS (P → U)

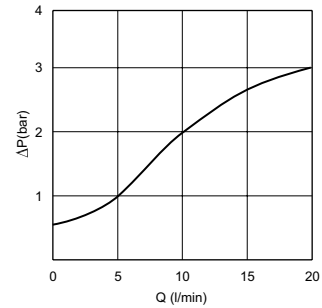

Fluid used: mineral based oil with viscosity 32 mm<sup>2</sup>/s at 50°C.

### ORDERING CODE

