

## ONE-WAY CHECK VALVES

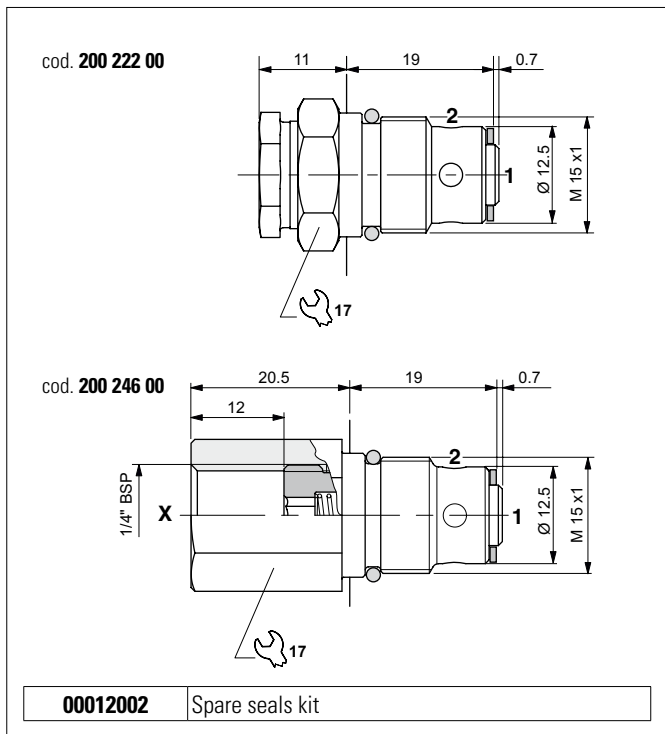

The unidirectional check valve allows oil to flow in only one direction. The guided ball seal is made of tempered and ground steel. The spring allows the valve to be mounted in any position. Also available with 1/4" BSP auxiliary pressure outlet. It has a galvanised steel body.

### HYDRAULIC FEATURES

Max. opening pressure	220 bar
Max. Flow	10 l/min
Max. Leakage (0 ÷ 5 drops/min)	0 ÷ 0.25 cm <sup>3</sup> /min
Crack pressure	1 bar
Hydraulic fluid	DIN 51524 Mineral oils
Fluid viscosity	10 ÷ 500 mm <sup>2</sup> /s
Fluid temperature	-25°C ÷ 75°C
Ambient temperature	-25°C ÷ 60°C
Max. contamin. level class with filter	ISO 4406:1999 - class 19/17/14
Tightening torque	16 ÷ 19 Nm
Cavity (M15x1)	CN033001 (See section 15)

### HYDRAULIC SYMBOLS

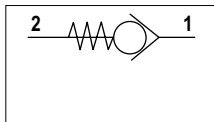

cod. 20022200

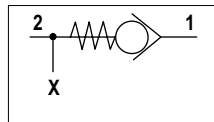

cod. 20024600

### ORDERING CODE

Code	Type	Weight
<b>20022200</b>	2 way	0.035 kg
<b>20024600</b>	3 way	0.042 kg

### PRESSURE DROPS

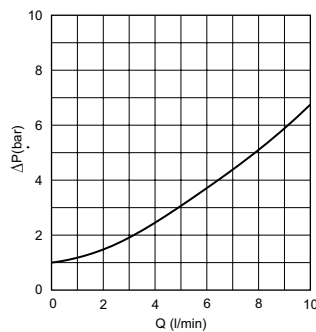

Fluid used: mineral based oil with viscosity 32 mm<sup>2</sup>/s at 50°C.