

ONE-WAY CHECK VALVES

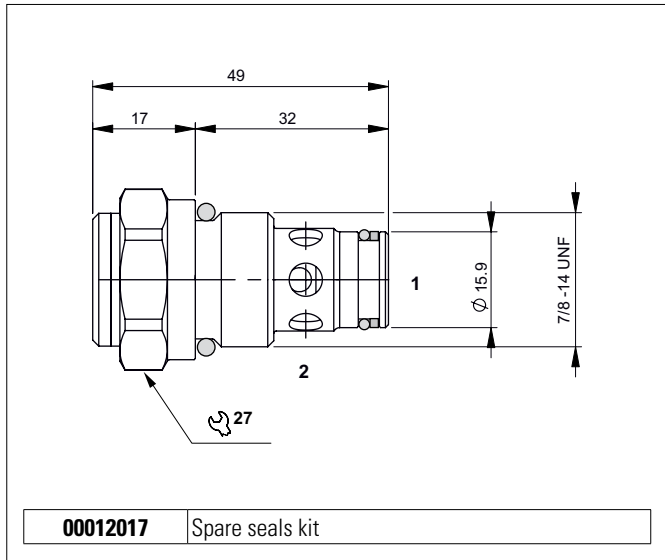

The check-valves permit one-directional oil flow only. On the opposite side the sealing is guaranteed by a hardened and ground taper steel poppet. The spring permits an easy valve installation in any position. External steel body protected on surface by zinc plating.

HYDRAULIC FEATURES

Max. opening pressure	350 bar
Max. Flow	60 l/min
Max. Leakage (0 ÷ 5 drops/min)	0 ÷ 0.25 cm ³ /min
Hydraulic fluid	DIN 51524 Mineral oils
Fluid viscosity	10 ÷ 500 mm ² /s
Fluid temperature	-25°C ÷ 75°C
Ambient temperature	-25°C ÷ 60°C
Max. contamin. level class with filter	ISO 4406:1999 - class 19/17/14
Weight	0.10 kg
Tightening torque	35 ÷ 40 Nm
Cavity (7/8 - 14 UNF)	CD019007 (See section 15)

HYDRAULIC SYMBOL

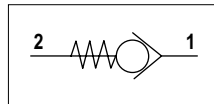

PRESSURE DROPS

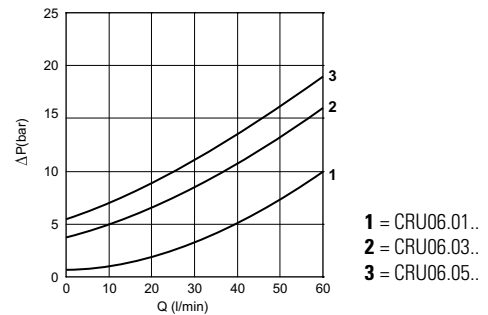

Fluid used: mineral based oil with viscosity 46 mm²/s at 40°C.

ORDERING CODE

