

JC.5.D... HEAVY DUTY SINGLE JOYSTICK BASE



JC5D...

This is a rugged joystick with potentiometer and ergonomic handle. The joystick has a spring return lever for center position. Single axis Y or dual axes XY are available. The panel material for this joystick and thickness must be strong and rigid. The panel thickness should have a dimension of minimum 3.5mm and maximum 6mm. The joystick has two directional micro-switches per axis. The handle has 5 pushbuttons and it is possible to have the operator present switch too.

The IP protection of joystick is referred to above mounting panel and it can be max. IP65. N.B. below mounting panel the rating is IP40.

APPLICATIONS

The joystick has been designed for aerial platform, agricultural and forestry machinery. The use of this product with the Aron electronic control unit for non contemporary movements gives the maximum advantage for hydraulic solutions controlled with a proportional valve.

Electrical features	
Potentiometer resistance	1.4 ÷ 2.2 KΩ
Max. supply voltage	VDD = 32V DC
Max. supply voltage X and Y pot	0 – 100% VDD
Max. output current	5 mA
Directional switches	
Maximum supply voltage	VCC = 32V DC
Max. output current	200 mA
	Resistive load
Mechanical features	
Mechanical angle	± 20°
Maximum operating load (Measured 130 mm above the mounting surface)	390 N
Mechanical Life (X and Y axis)	7.500.000 cycles
Weight (handle include)	0,900 Kg
Ambient operating temperature	-40°C ÷ +80°C
Protection according to DIN	IP65
Shocks	Level 20G Type ½ sine 6ms
	Number of shocks 1350 each axis

ORDERING CODE

- JC** Heavy duty single Joystick
- 5** Handle (5 switches)
- D** Directional switches
- *** Functional operation
1 = single axis (Y)
2 = dual axis (XY)
- *** **A** = With operator present trigger switch
B = Without operator present trigger switch
- 00** No variants
- 1** Serial number

- **CE** Registered mark for industrial environment with reference to the compatibility. European norms:
 - IEC 61000-4-3 "Electromagnetic immunity"
 - EN6550022 "Electromagnetic emissions"
- Product in accordance with **RoHS** 2002/95/CE Europe Directive.

Connectors and electrical contacts included in the furniture.

9

POTENTIOMETER OUTPUT AXIS X,Y

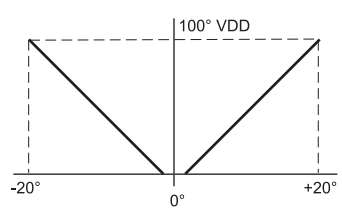

In order to obtain the output signal from the joystick as indicated in the diagram over it is necessary:

- for the X axis output signal, connect the pin 3 and 5 of the AMP 16 way connector at +VDD, and connect the pin 6 of the AMP 16 way connector at 0V.
- for the Y axis output signal, connect the pin 9 and 11 of the AMP 16 way connector at +VDD, and connect the pin 12 of the AMP 16 way connector at 0V.

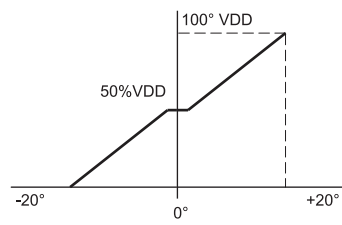

In order to obtain the output signal from the joystick as indicated in the diagram over it is necessary:

- for the X axis output signal, connect the pin 3 of the AMP 16 way connector at 0V, and connect the pin 5 of the AMP 16 way connector at +VDD.
- for the Y axis output signal, connect the pin 9 of the AMP 16 way connector at 0V, and connect the pin 11 of the AMP 16 way connector at +VDD.

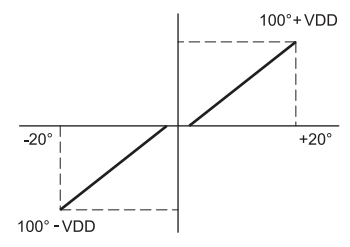

In order to obtain the output signal from the joystick as indicated in the diagram over it is necessary:

- for the X axis output signal, connect the pin 3 of the AMP 16 way connector at -VDD, and connect the pin 5 of the AMP 16 way connector at +VDD.
- for the Y axis output signal, connect the pin 9 of the AMP 16 way connector at -VDD, and connect the pin 11 of the AMP 16 way connector at +VDD.

CONNECTOR CONFIGURATION AND PIN ALLOCATION DETAIL

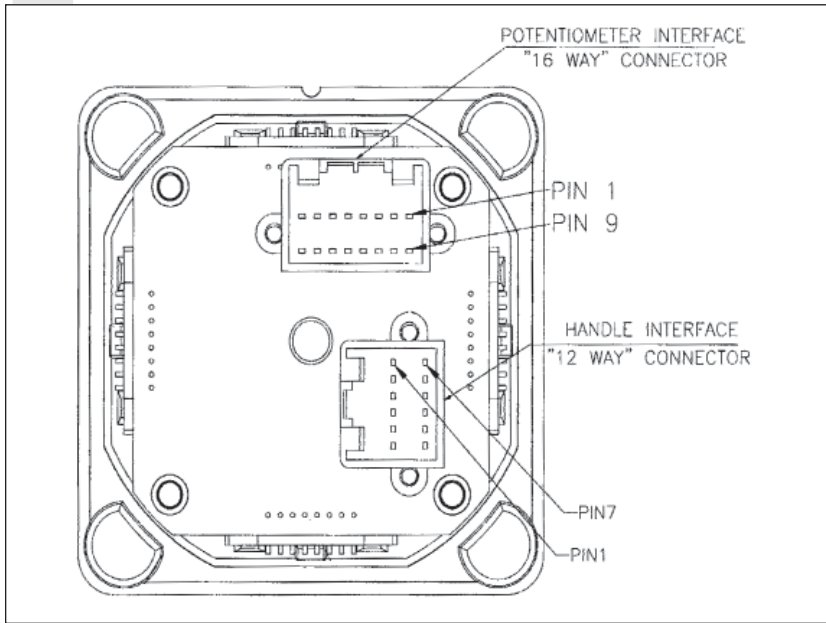

12 WAY HANDLE CONNECTIONS

AMP	Pin allocation description
1	Switch 4 - contact N/O
2	Switch 3 - contact N/O
3	Switch 2 - contact N/O
4	Switch 1 - contact N/O
5	Switch 5 - contact N/O
8	Operator present trigger switch
11	Switch track common
12	Operator present trigger switch

OVERALL DIMENSIONS

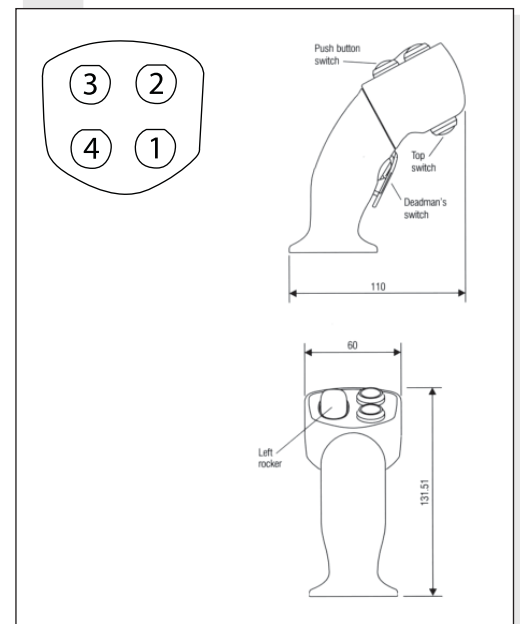

16 WAY PRIMARY POTENTIOMETER CONNECTIONS

AMP	Pin allocation description
Single potentiometer per axis	
1	Y Switch track forward
2	X Switch track centre on
3	X Pot track left
4	X Pot track signal
5	X Pot track right
6	X Pot track centre tap
7	X Switch track common
8	X Switch track left
9	Y Pot track back
10	Y Pot track signal
11	Y Pot track forward
12	Y Pot track centre tap
13	Y Switch track common
14	Y Switch track back
15	X Switch track right
16	Y Switch track centre on

HANDLE ADAPTER PLATE

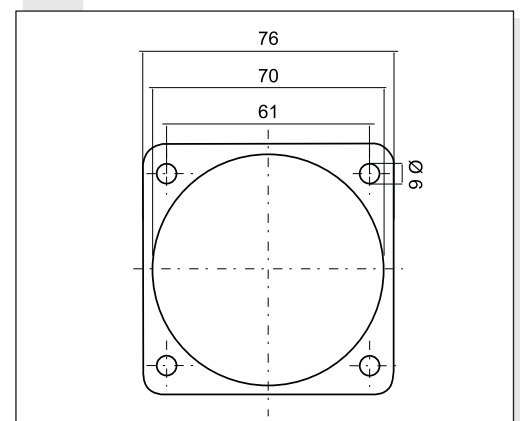

SPARE PARTS AMP 040 SERIES MULTILOCK

Receptacle contacts
P.No. 175062-1* Loose piece

Plug housing 12 position
P.No. 174045-2*

Plug housing 16 position double row
P.No. 174046-2*

* AMP code

Spare parts kit, connectors and electrical contacts: V89900000

ANALOGUE JOYSTICK CONTROLLERS

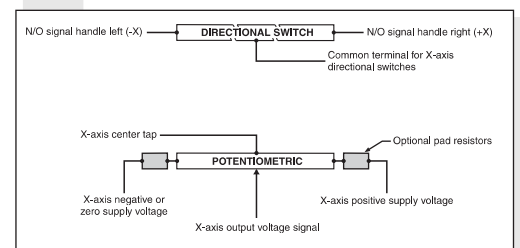

9