

SHUTTLE VALVES

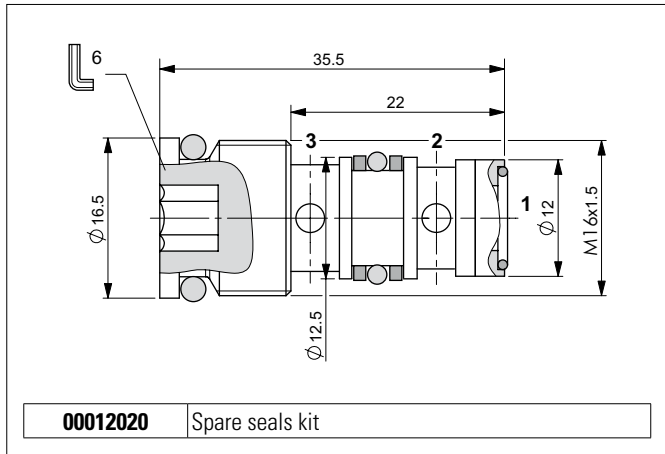

The shuttle type cartridge valves allow taking of the highest pressure signal to the external port via displacement of ball in tempered and ground steel. There are usually employed to signal the actuator load to a load sensing pump pressure compensator. External steel body protected on surface by zinc plating.

HYDRAULIC SYMBOL

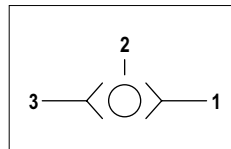

HYDRAULIC FEATURES

Max. opening pressure	380 bar
Max. Flow	10 l/min
Max. Leakage (0 ÷ 5 drops/min)	0 ÷ 0.25 cm ³ /min
Hydraulic fluid	DIN 51524 Mineral oils
Fluid viscosity	10 ÷ 500 mm ² /s
Fluid temperature	-25°C ÷ 75°C
Ambient temperature	-25°C ÷ 60°C
Max. contamin. level class with filter	ISO 4406:1999 - class 19/17/14
Weight	0.029 kg
Tightening torque	16 ÷ 18 Nm
Cavity (M16x1.5)	CN037003 (See section 15)

ORDERING CODE

Code	Type
RVLV0101160	Shuttle valve

PRESSURE DROPS

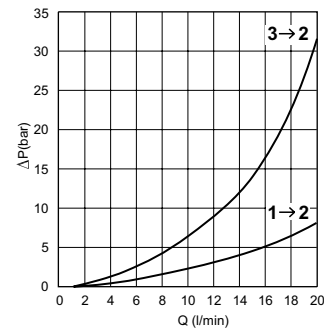

Fluid used: mineral based oil with viscosity 46 mm²/s at 40°C.