

PUMP UNLOADING VALVES

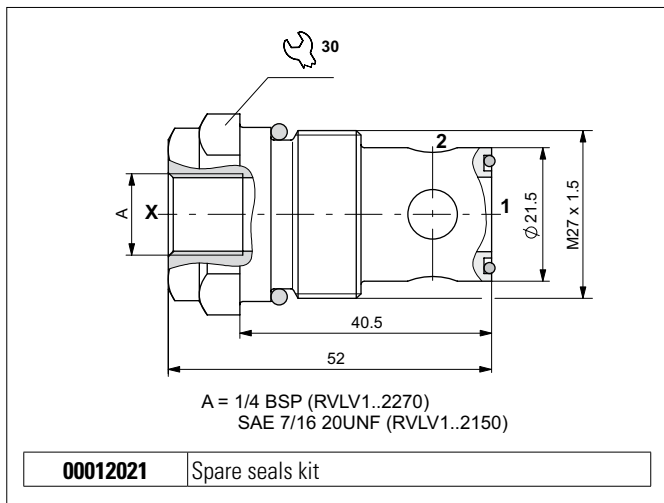

The normally-closed 2-way 2-position valve is used to connect a normally pressurised branch to the outlet in order to allow fluid to flow through the valve from 2 to 1.

Tapered poppet in tempered and ground steel, released when the pilot branch X is connected to the outlet.

It has a galvanised steel body.

HYDRAULIC FEATURES

Max. opening pressure	380 bar
Max. Flow	140 l/min
Max. Leakage (0 ÷ 5 drops/min)	0 ÷ 0.25 cm ³ /min
Hydraulic fluid	DIN 51524 Mineral oils
Fluid viscosity	10 ÷ 500 mm ² /s
Fluid temperature	-25°C ÷ 75°C
Ambient temperature	-25°C ÷ 60°C
Max. contamin. level class with filter	ISO 4406:1999 - class 19/17/14
Weight	0.1422 kg
Tightening torque	22 ÷ 26 Nm
Cavity (M27x1.5)	CN059001 (See section 15)

HYDRAULIC SYMBOL

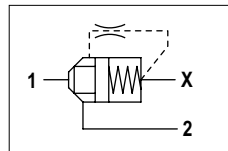

ORDERING CODE

Code	Type
RVLV1202270	Pump unloading valve (A = 1/4 BSP)
RVLV12021S0	Pump unloading valve (A = SAE 7/16 20UNF)

PRESSURE DROPS

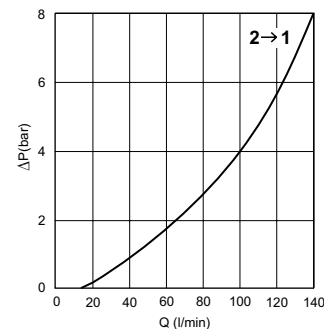

Fluid used: mineral based oil with viscosity 46 mm²/s at 40°C.